

"Optical" Compact Dryers

SHINI "Optical" Compact Dryers combine the functions of dehumidifying, drying and two-stage conveying into one single unit, specified for the production of "optical grade" products, such as Lenses, LCD backlight panel, compact discs, etc. They feature honeycomb rotor for dehumidifying, ensuring continuous and constant low dew point. All material contact surfaces are made of stainless steel (Mirror polished) and high efficiency particulate air filter (HEPA) with a filtration efficiency of 99.97% can ensure no material contamination.

Features:

- Equipped with honeycomb-rotor for dehumidifying, ensuring continuous and constant supply of low dew-point air.
- Suitable for all optical applications.
- Integration of dehumidifying, drying and two-stage conveying as standard with three-stage conveying as an option.
- Units processing is controlled via microprocessor as standard with touch screen PLC control as an option for centralized and automatic operation.
- Optional dew-point indicator.
- Insulated drying hopper with air down-blowing and cyclone exhaust design to ensure a constant temperature and improved drying efficiency.
- All material contact surfaces are polished with close loop conveying to prevent material contamination and moisture absorption.
- Pneumatic shut-off valve to ensure no material left over in the material line after each loading cycle.
- Two condensers design to ensure low return air temperature and low dew-point.
- Requirement Cyclone dust separator can be attached to prevent material contamination on .
- Air intake filter is optional for preventing air particulate from entering to the material.
- High efficiency particulate (HEPA) air filter with filtration efficiency 99.97% can remove fine particulates as small as 0.3 μ m.



HEPA air filter

Working Principle Illustration

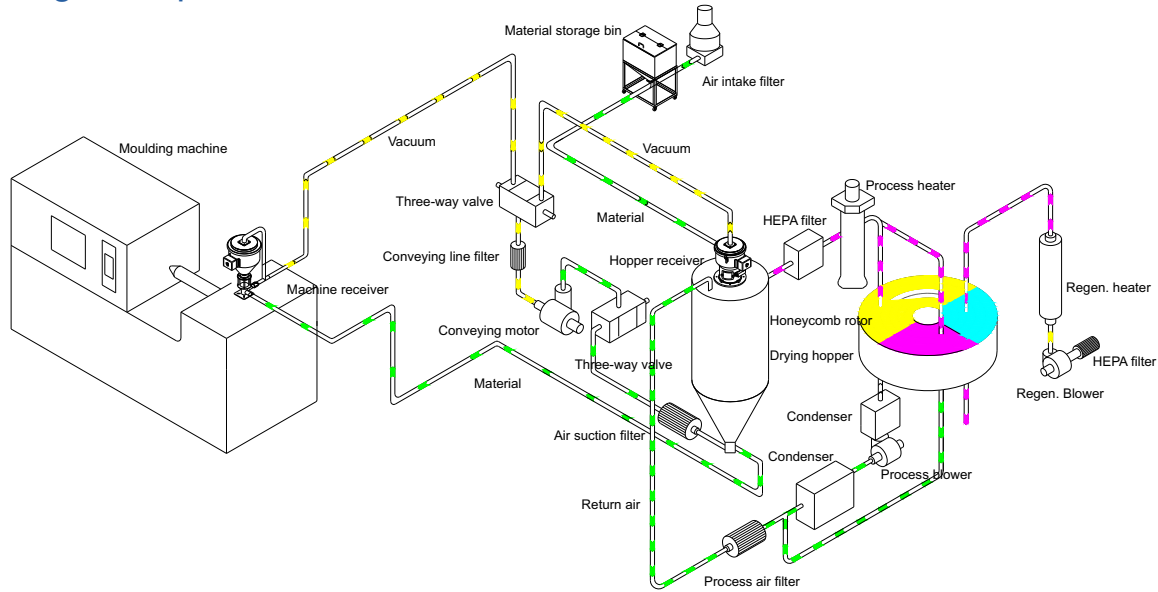

Dew-point comparison

Dew-point (°C)	Relative humidity (%)	Moisture content	
		PPM	%
+20	100	23,072	2.307
+10	52.50	12,117	1.212
0	26.10	6,027	0.603
-10	11.20	2,574	0.257
-20	4.40	1,025	0.103
-30	1.60	378	0.038
-40	0.60	128	0.013
-50	0.20	39	0.004

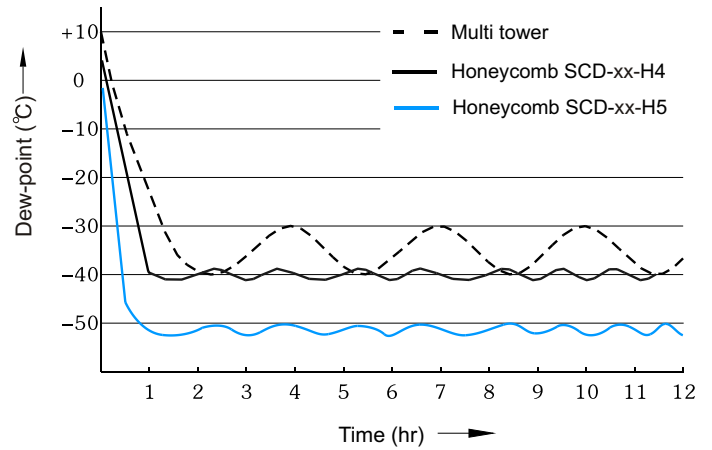

Dust Eliminating Hopper

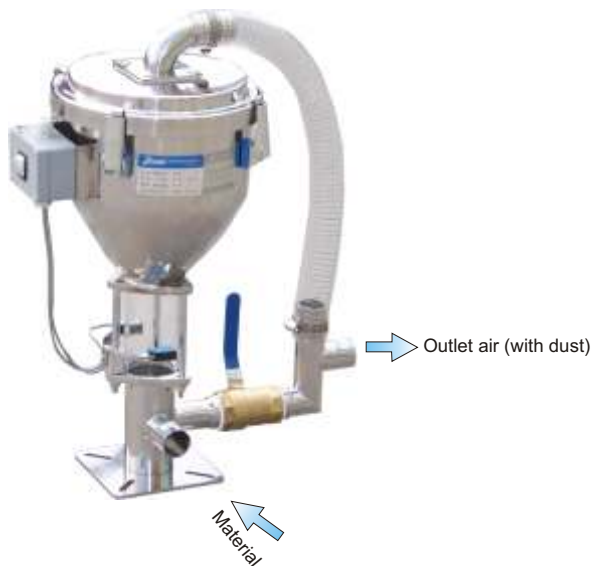

For application in "optical grade" products, the specially designed vacuum port of this unit creates air circulation when loading material to get rid of fine particulate powder in material line.

Cyclone Dust Separator



Cyclone dust separator is used to keep air in conveying line clean and to reduce filter cleaning frequency.

Operator panel for standard control



Standard panel without dew-point monitor



Optional panel with dew-point monitor

Illustrations for optional touch screen



Drying process screen



Conveying process screen

Optional Features

- Under ideal conditions, models H5 can supply dehumidified dry air with a dew-point of -50°C .
- Three-stage conveying functions to serve two moulding machines.
- LCD touch screen PLC controller.
- Dew-point monitor to monitor and display the dry air dew-point.
- Cyclone dust separator.
- Air inlet filter.

For serving one machine:
Two-stage conveying system (standard feature)

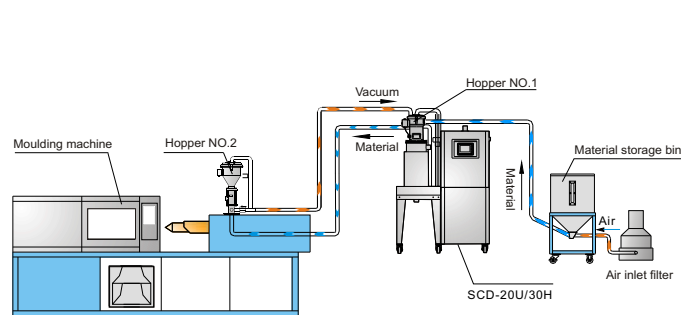

For serving two machines:
Three-stage conveying system (optional feature)

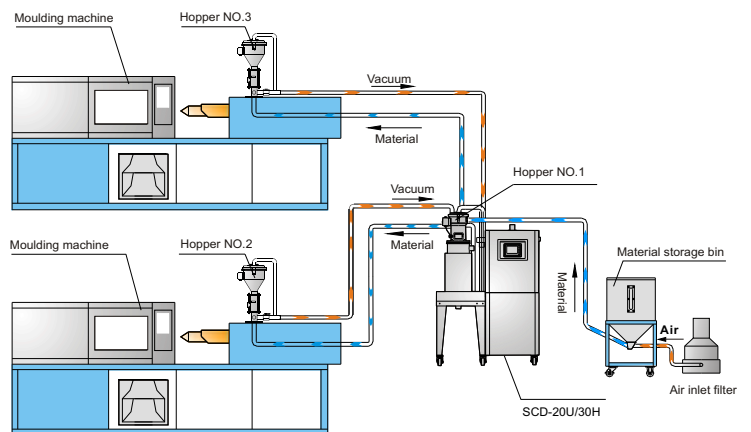

Specifications

Model (Optical grade)	SCD-20U/30H-OP	SCD-40U/30H-OP	SCD-80U/50H-OP	SCD-120U/80H-OP
Drying system				
Drying hopper capacity (L)	20	40	80	120
Process heater power (kw)	3	3	3.9	6
Process blower power (kw)	0.2	0.2	0.4	0.75
Dehumidifying system				
Dry air capacity (m ³ /hr)	30	30	50	80
Regen. heater power (kw)	3	3	3	3.5
Regen. blower power (kw)	0.2	0.2	0.2	0.2
Conveying system				
Conveying blower power (kw)	0.75	0.75	0.75	0.75
Dia. of conveying hose (inch)	1.5	1.5	1.5	1.5
SHR-U-E hopper receiver (L)	3	3	6	6
SHR-U hopper receiver (L)	6	6	6	6
Dimensions				
H (mm)	1400	1500	1650	1650
W (mm)	890	890	958	958
D (mm)	1050	1050	1240	1240
Weight (kg)	235	280	328	385

We reserve the right to change specifications without prior notice.

Outline Drawing

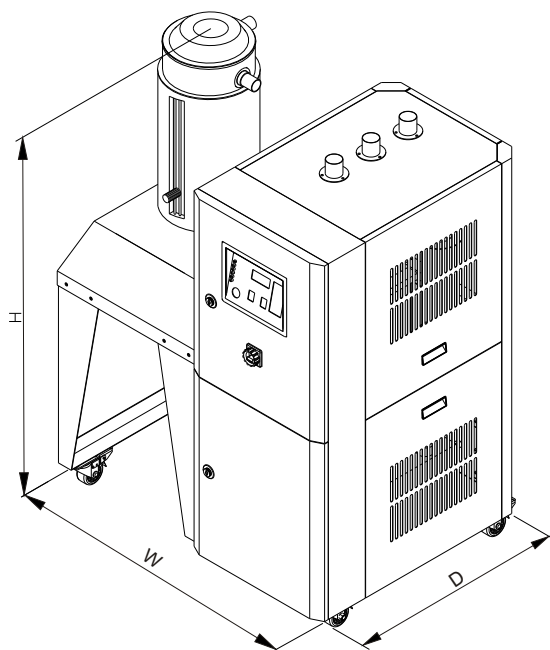

Výrobce:

Shini Plastics Technologies, Inc.

Corporate Strategic Center:

Jinshagang Industrial Zone, Dalang,
Dongguan, Guangdong, P.R.China.

Telephone: +86 (0)769 8111 6600

Facsimile: +86 (0)769 8111 6611

Email: shini @ shini.com

www.shini.com

Distributor:

A.M. spol. s r.o.

Sladovnická 167,
46311 Liberec,

Česká republika.

Tel: +420 482 750 037

Fax: +420 485 163 999

Email: info @ amcz.cz

www.amcz.cz